

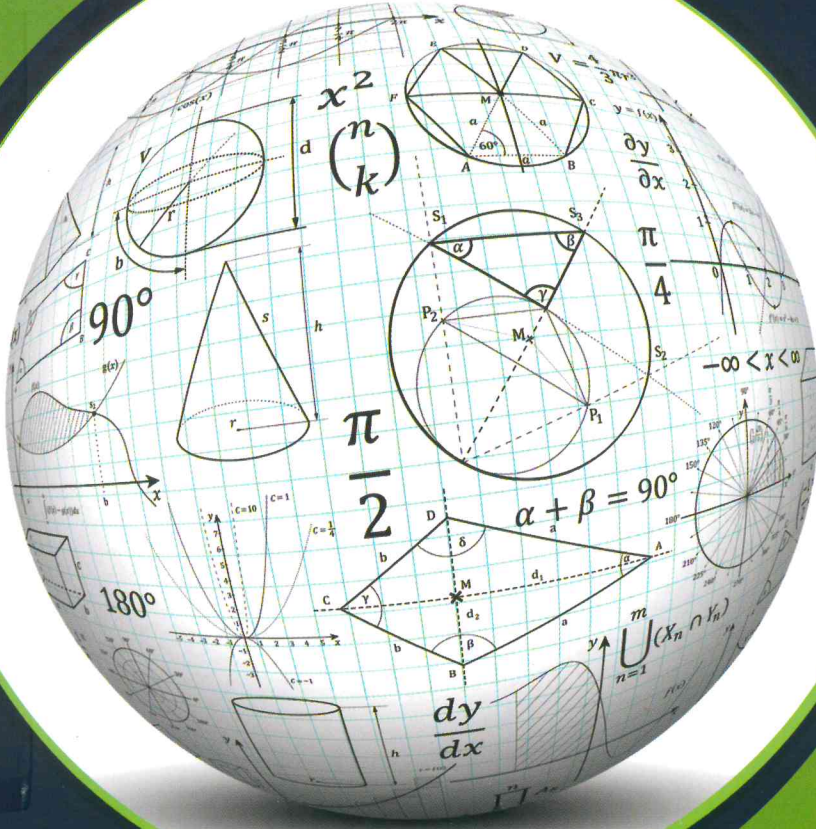

GALATA YÖS-SAT YAYINLARI

YÖS



# GEOMETRİ

## Geometry

Konu Anlatımlı Soru Bankası  
Question Bank with Subject Lecture

Yeni Tarz Sorular New Style Questions

# ÖNSÖZ

Değerli Öğretmenler ve Sevgili Öğrenciler,

Galata Eğitim Kurumları, 2005'ten bugüne YÖS, SAT ve TÖMER sınavlarına hazırlanan öğrencilere eğitim ve öğretim faaliyetlerinin yanı sıra rehberlik hizmetleri de veren bir eğitim kurumudur.

Kurumumuz, ülkemizde YÖS'e girecek olan öğrencilere ve dünyanın farklı yerlerinden ülkemize gelen uluslararası öğrencilere YÖS'e hazırlanma aşamasında şu hizmetleri vermektedir:

- Ders çalışma teknikleri,
- Üniversite ve bölüm bilgileri,
- Başvuru ve tercih aşamasında rehberlik hizmetleri.

Öğrencilerimizin bu aşamalardan doğru yönlendirmelerle geçerek adım adım başarıya ulaşması sağlanmaktadır.

Elinizde bulunan Geometri Konu Anlatımlı Soru Bankası Kitabı, üniversitelerin son yıllarda YÖS'te sormuş oldukları yeni tarz sorulara göre hazırlanmıştır. Bütün konuları kapsayacak şekilde her tarz sorudan hazırlanan kitabımız, sizleri başarıya ulaştıracak ve sınavlarda karşınıza çıkacak sorularda sizlere pratiklik kazandıracaktır. Değerli öğretmenlerimize ve sevgili öğrencilerimize faydalı olması dileğiyle.

## FOREWORD

*Dear Teachers and Students,*

*Galata Educational Institutions is an educational institution that has been providing education and training activities as well as guidance services to students preparing for YÖS, SAT, and TÖMER exams since 2005.*

*Our institution provides the following services to students who will enter YÖS in our country and international students who come to our country from different parts of the world in the stage of preparing for YÖS:*

- *Study techniques,*
- *University and department information,*
- *Providing guidance services at the application and selection stage.*

*It is ensured that our students reach success step by step by passing these stages with the right guidance.*

*The Geometry Subject Lecture + Question Bank Book you have has been prepared according to the new style questions that universities have recently asked in YÖS. Our book, which is prepared from all kinds of questions in a way that covers all subjects, will make you successful and give you practicality in the questions you will encounter in the exams. We hope it will be useful to our valuable teachers and dear students.*

## İÇİNDEKİLER (CONTENTS)

● GEOMETRİK KAVRAMLAR <i>GEOMETRIC CONCEPTS</i> .....	5	● YAMUK <i>TRAPEZOID</i> .....	291
● ÜÇGENDE AÇILAR <i>ANGLES IN TRIANGLE</i> .....	23	● DELTOİD <i>DELTOID</i> .....	313
● DİK ÜÇGEN <i>RIGHT TRIANGLE</i> .....	47	● DİKDÖRTGEN <i>RECTANGULAR</i> .....	323
● İKİZKENAR ÜÇGEN <i>ISOSCELES TRIANGLE</i> .....	69	● KARE <i>SQUARE</i> .....	343
● EŞKENAR ÜÇGEN <i>EQUILATERAL TRIANGLE</i> .....	85	● ÇEMBERDE AÇI <i>ANGLES IN A CIRCLE</i> .....	361
● AÇIORTAY <i>BISECTOR</i> .....	101	● ÇEMBERDE UZUNLUK <i>CIRCLE LENGTH</i> .....	387
● KENARORTAY <i>MEDIAN</i> .....	117	● DAİREDE ALAN <i>AREA OF A CIRCLE</i> .....	409
● ÜÇGENDE BENZERLİK <i>SIMILARITY IN TRIANGLES</i> .....	133	● NOKTANIN ANALİTİK İNCELEMESİ <i>ANALYTICAL REVIEW OF THE POINT</i> .....	429
● ÜÇGENDE ALAN <i>AREA IN TRIANGLE</i> .....	161	● DOĞRUNUN ANALİTİK İNCELEMESİ <i>ANALYTICAL EXAMINATION OF THE LINE</i> .....	447
● ÜÇGENDE MERKEZLER <i>CENTERS IN TRIANGLE</i> .....	183	● SİMETRİ <i>SYMMETRY</i> .....	475
● AÇI – KENAR BAĞINTISI <i>ANGLE – EDGE RELATION</i> .....	193	● ÇEMBERİN ANALİTİK İNCELEMESİ <i>ANALYTICAL REVIEW OF THE CIRCLE</i> .....	487
● ÇOKGENLER <i>POLYGONS</i> .....	211	● PRİZMALAR VE DAİRESEL SİLİNDİR <i>PRISMS AND CIRCULAR CYLINDER</i> .....	505
● DÖRTGENLER <i>QUADRILATERALS</i> .....	231	● PİRAMİTLER <i>PYRAMIDS</i> .....	525
● PARALELKENAR <i>PARALLELOGRAM</i> .....	249	● VEKTÖRLER <i>VECTORS</i> .....	545
● EŞKENAR DÖRTGEN <i>EQUILATERAL QUADRANGLE</i> .....	279		

# ÜNİTE 1

## Unit 1

**Geometrik Kavramlar**

*Geometric Concepts*



## Geometrik Kavramlar / Geometric Concepts

## Nokta (Point):

 A noktası (Point A)

- » Büyük harfle gösterilir. Boyutsuzdur.  
(It is indicated with a capital letter. It is dimensionless.)

## Doğru (Line):

 AB doğrusu (AB line)

- » Her iki yönden sonsuza giden noktalar kümesidir.  
(It is a set of points that go from both directions to infinity.)

## Işın (Beam):

 [AB ışını ([AB beam)

- » Belirli bir başlangıç noktası olup diğer yönden sonsuza giden noktalar kümesidir.  
(It is a set of points that is a specific starting point and goes the other way to infinity.)

## Doğru parçası (Line segment):

 [AB] doğru parçası ([AB] line segment)

 (AB] doğru parçası ((AB] line segment)

- » Her iki ucu da sınırlı noktalar kümesidir.  
(Both ends are limited set of points.)

## Açı ve Açı Çeşitleri / Angle and Angle Models

## Açı (Angle):

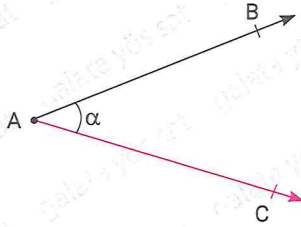

- [AB ve [AC ışın ([AB and [AC beam)
- $[AB \cup [AC = \widehat{BAC} = \widehat{CAB} = \widehat{A}$  şeklinde yazılır.
- BAC açısının ölçüsü  $\alpha$ 'dır.  
(The measure of the angle BAC is  $\alpha$ .)
- $m(\widehat{BAC}) = \alpha$  şeklinde gösterilir. (It is denoted as  $\alpha$ .)

## Açı Çeşitleri (Angle Types)

## 1. Dar Açı (Acute Angle)

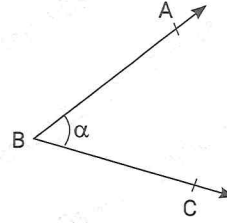

$$0^\circ < \alpha < 90^\circ$$

## 2. Dik Açı (Right Angle)

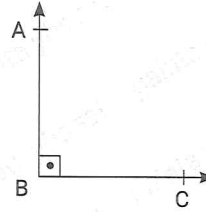

$$[BA \perp [BC \\ \Rightarrow \alpha = 90^\circ$$

## 3. Geniş Açı (Obtuse Angle)

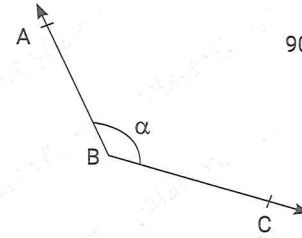

$$90^\circ < \alpha < 180^\circ$$

## 4. Doğru Açı (Straight Angle)

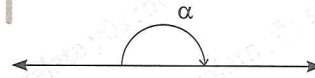

$$\alpha = 180^\circ$$

## 5. Tam Açı (Complete Angle)

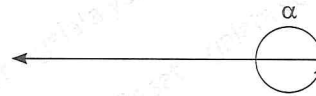

$$\alpha = 360^\circ$$

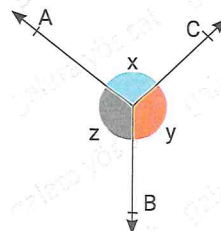

$$x + y + z = 360^\circ$$

**Tümler Açı (Complementary Angle)**

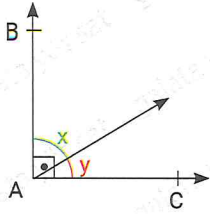

$[AB \perp AC]$   
 $x + y = 90^\circ$

» Birbirini  $90^\circ$  tamamlayan komşu açılara denir.  
(Neighboring angles that complement each other by  $90^\circ$ .)

**Bütünler Açısı (Supplementary Angle)**

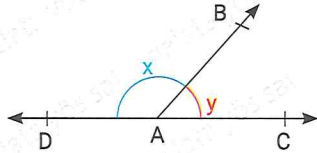

$x + y = 180^\circ$

» Birbirini  $180^\circ$  tamamlayan komşu açılara denir.  
(Neighboring angles that complement each other  $180^\circ$ .)

**Ters Açılar (Reverse Angles)**

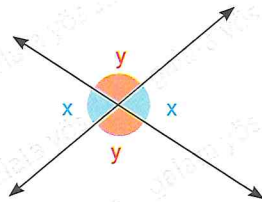

**Açıortay (Bisector)**

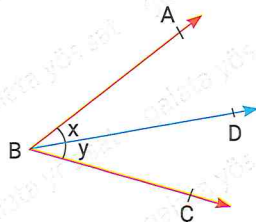

$[BD \text{ açıortay (BD bisector)}]$   
 $\Rightarrow x = y$

» Bir açıyı iki eşit parçaya bölen ışına **açıortay** denir.  
(A ray that divides an angle into two equal parts is called the bisector.)



Unutma / Don't forget

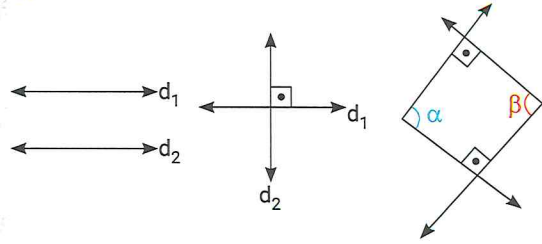

$d_1 \parallel d_2$        $d_1 \perp d_2$

$\parallel \rightarrow$  paralel sembolü (parallel symbol)       $\perp \rightarrow$  diklik sembolü (steepness symbol)       $\alpha + \beta = 180^\circ$

**Üçgen Çeşitleri / Triangle Types**

**Çeşitkenar Üçgen (Scalene Triangle)**

$a + b + c = 180^\circ$   
 $a \neq b \neq c$   
 $x \neq y \neq z$

» Bütün kenarları ve açıları farklı olan üçgendir.  
(It is a triangle with all different sides and angles.)

**İkizkenar Üçgen (Isosceles Triangle)**

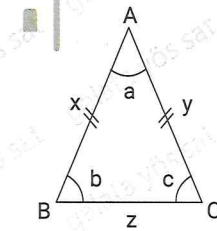

$|AB| = |AC| \Rightarrow x = y \neq z$   
 $b = c \neq a$

» İki kenarı ve bu kenarları gören taban açıları eşit olan üçgendir.  
(The two sides and the base that sees these sides is a triangle with equal angles.)

**Eşkenar Üçgen (Equilateral Triangle)**

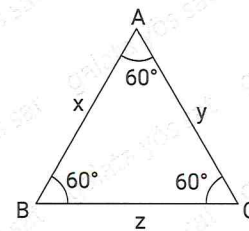

$|AB| = |AC| = |BC|$   
 $x = y = z$

» Bütün kenarları birbirine eşit olan üçgendir.  
(It is a triangle with all sides equal to each other.)  
» İç açıları da birbirine eşit ve  $60^\circ$ 'dir.  
(Internal angles are equal to each other and  $60^\circ$ .)

Paralel İki Doğru Arasında Oluşan Açı Modelleri  
Angle Models Composed Between Two Parallel Lines

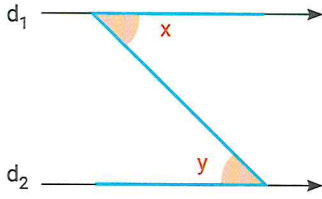

$d_1 \parallel d_2$   
 $x = y$

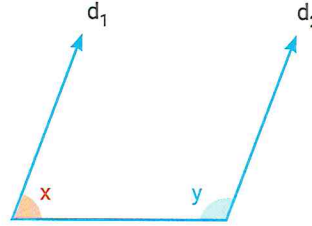

$d_1 \parallel d_2$   
 $x + y = 180^\circ$

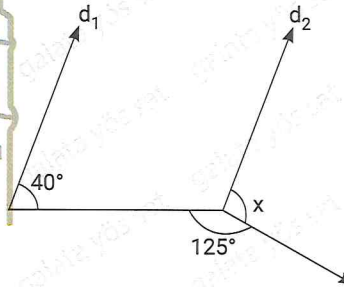
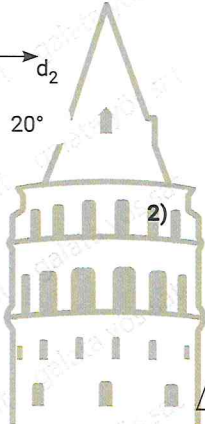
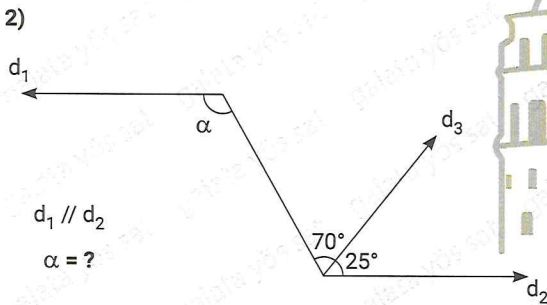
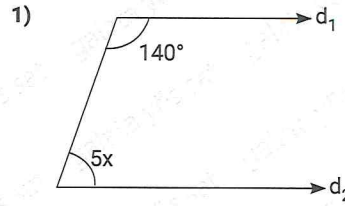
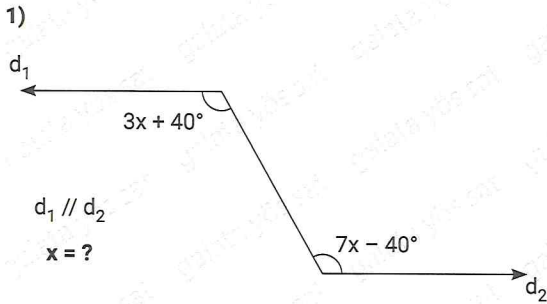

! ( Sence burada kaç tane Z modeli var?

(How many Z models do you think are there?)

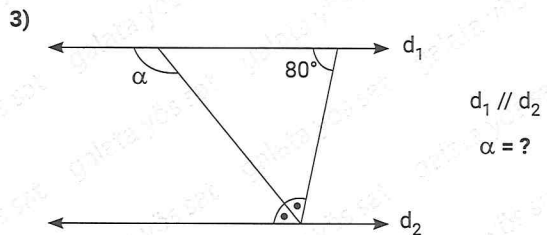
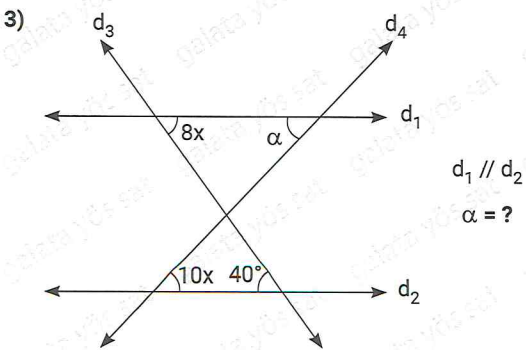

50°

130°



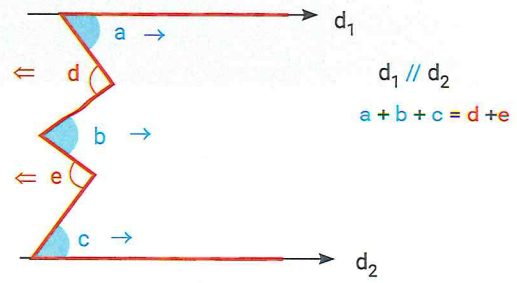
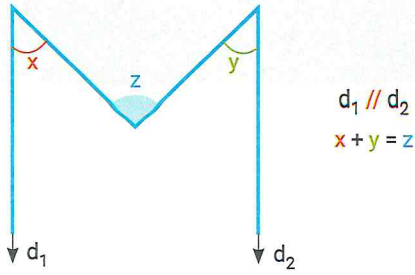

» Sağ yöne bakan açılarn ölçülerinin toplamı, sol yöne bakan açılarn ölçülerinin toplamına eşittir.  
(The sum of the dimensions of the angles facing the right is equal to the sum of the dimensions of the angles facing the left.)

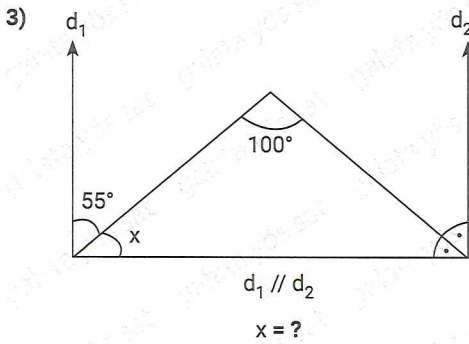
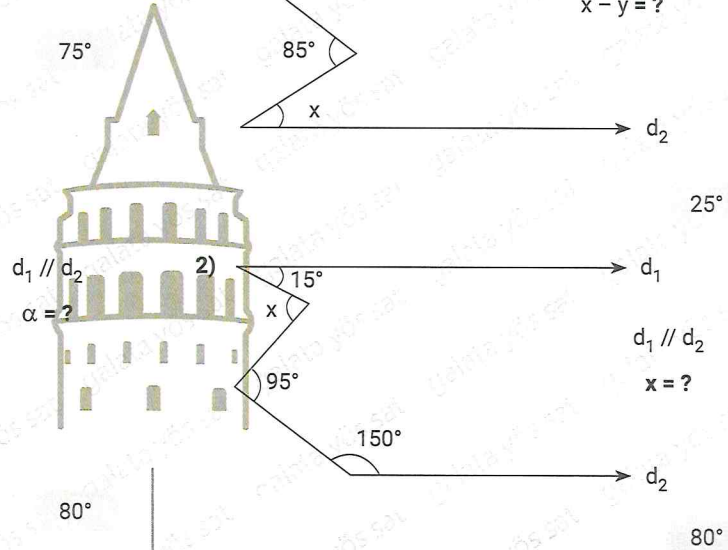
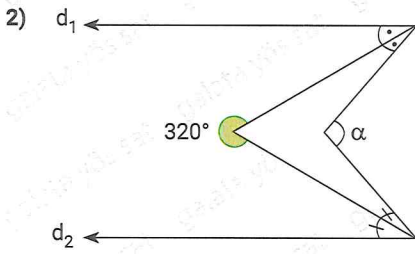
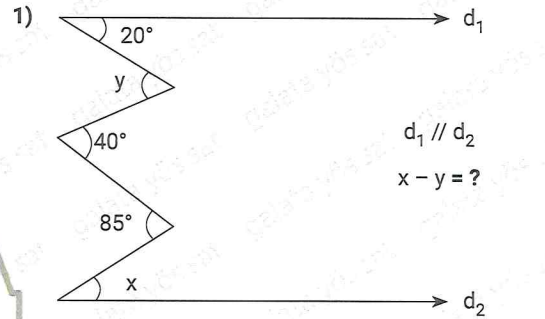
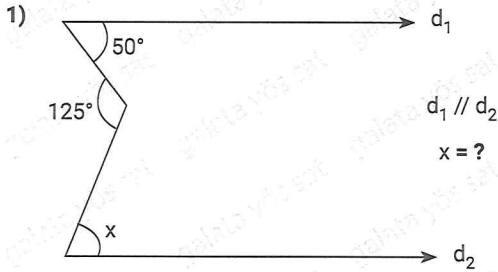

**İpucu (Tip) / Hint**

- Zigzag çizerken dar açıyla başlayıp dar açıyla bitirmen gerekir.  
(When drawing a zigzag, it is necessary to start with an acute angle and end with an acute angle.)

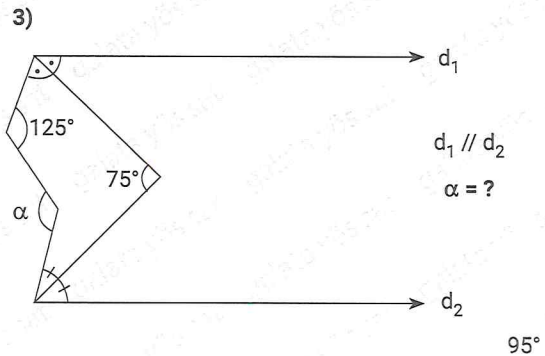

Kalem Ucu Modeli / Pen Tip Model

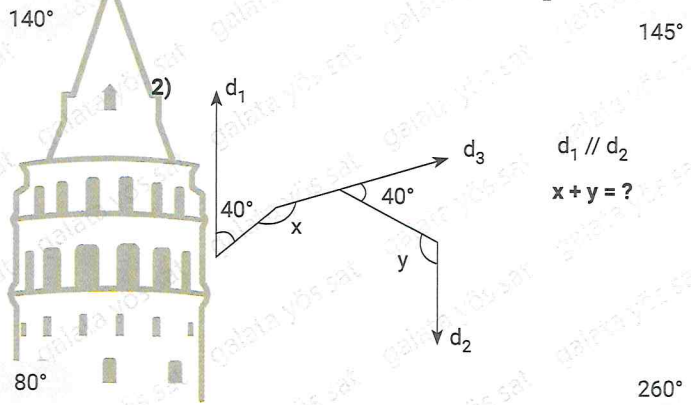
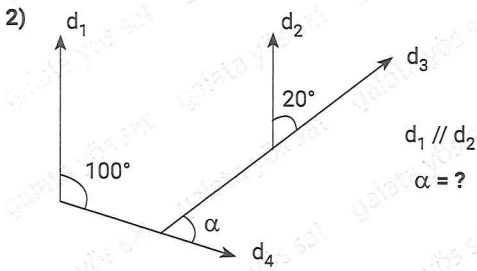
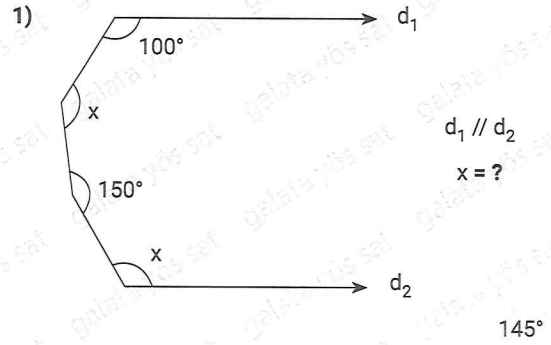
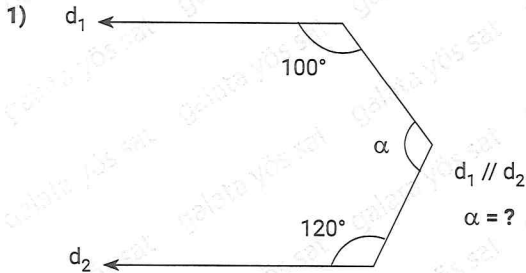
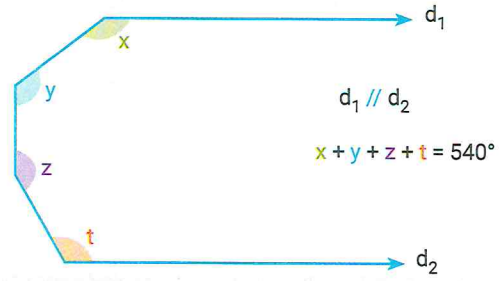
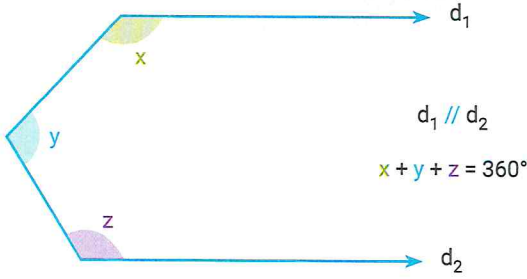

İpucu (Tip) / Hint

- Burada sadece  $d_1$  ve  $d_2$  paraleline yoğunlaşman gerekir. (Here we just have to concentrate on  $d_1$  and  $d_2$  parallel.)

İpucu (Tip) / Hint

- Şekillerin dönmesi kafanı karıştırmasin! Paralel doğrulara bakmak işini kolaylaştırır. (Do not be confused by the rotation of the shapes! Looking at parallel lines makes it easy.)

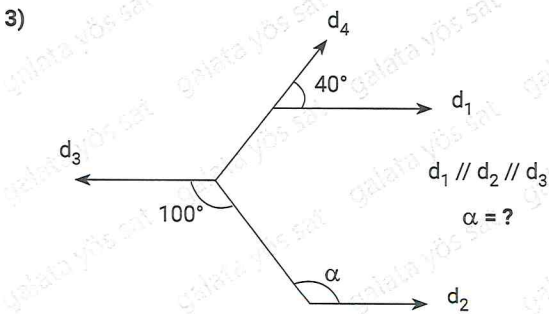

3)  $2 m(\widehat{ABC}) = 3 m(\widehat{BCD}) = m(\widehat{CDE}) = 6 m(\widehat{DEF})$

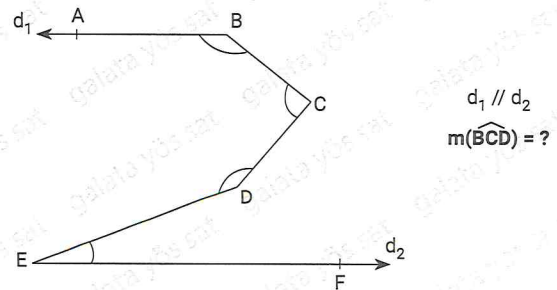

100°

72°

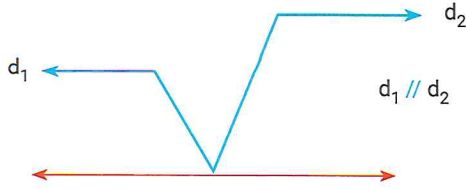

**İpucu (Tip) / Hint**

- Burada  $d_1 // d_2$ 'dir. Ancak Z, U ve M modellerinden biri olmadığını farketmiş olmalısın.  
(Here  $d_1 // d_2$ . But you must have noticed that it is not one of the Z, U, and M models.)
- Bu semboller bulmak için sivri köşeden paralel yönünde bir paralel çizmelisin.  
(To find these symbols, you need to draw a parallel direction from the pointed corner.)

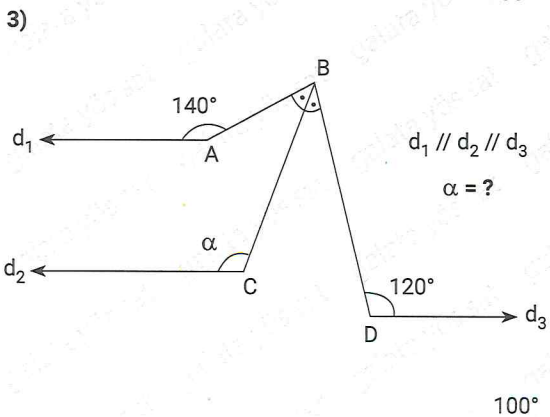
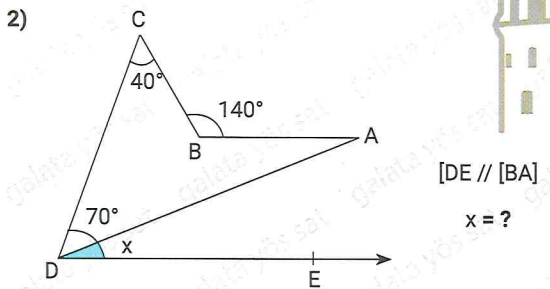
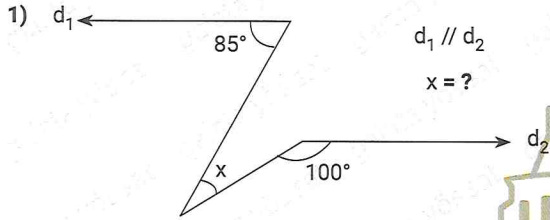

**Neler Öğrendik? / What Have We Learned?**

»  $d_1 // d_2$  olmak şartıyla

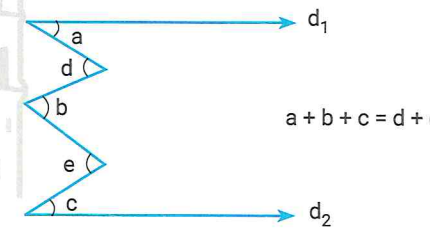
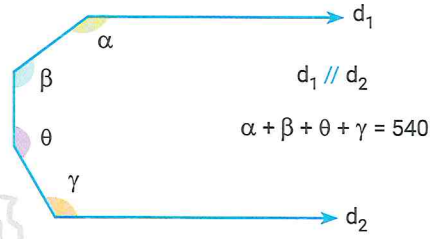
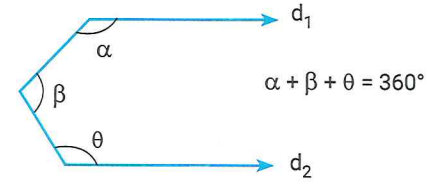
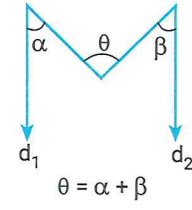
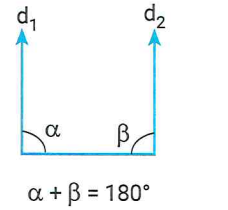
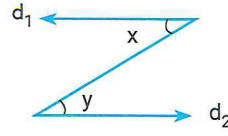

olarak özetleyebiliriz.

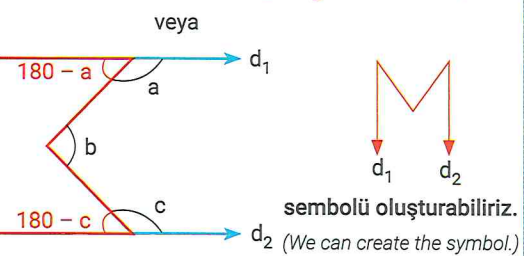
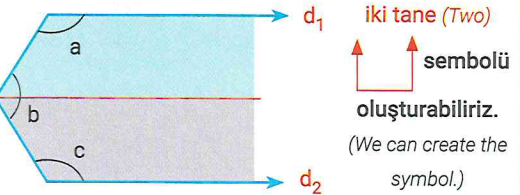

**Yani paralelleri uzatmaya korkma!**

(So don't be afraid to extend the parallels!)

1.

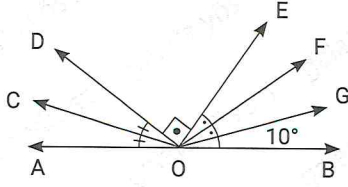

A, O, B doğrusal, [OC ve [OF açıortay

A, O, B linear, [OC and [OF bisector

$$m(\widehat{GOB}) = 10^\circ$$

Yukarıdaki verilere göre,  $m(\widehat{COF})$  kaç derecedir?

(Based on the above data, how many degrees is  $m(\widehat{COF})$ ?)

- A) 100 B) 130 C) 140 D) 150 E) 160

2.

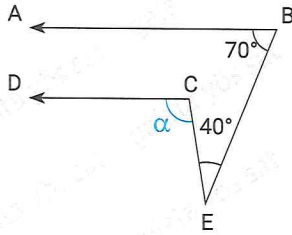

[BA // [CD

$$m(\widehat{EBA}) = 70^\circ$$

$$m(\widehat{BEC}) = 40^\circ$$

Yukarıdaki verilere göre,  $m(\widehat{DCE}) = \alpha$  kaç derecedir?

(Based on the above data, how many degrees is  $m(\widehat{DCE}) = \alpha$ ?)

- A) 110 B) 120 C) 130 D) 140 E) 150

3.

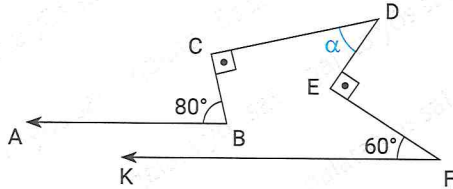

[BA // [FK,  $m(\widehat{CBA}) = 80^\circ$

$$m(\widehat{DCB}) = m(\widehat{DEF}) = 90^\circ, m(\widehat{EFK}) = 60^\circ$$

Verilenlere göre,  $m(\widehat{CDE}) = \alpha$  kaç derecedir?

(Based on the above data, how many degrees is  $m(\widehat{CDE}) = \alpha$ ?)

- A) 10 B) 20 C) 30 D) 40 E) 50

4. Tümleri ile bütünlerinin toplamı  $210^\circ$  olan açı kaç derecedir?

(What is the angle in which the sum of supplement and complement is  $210^\circ$ ?)

- A) 20 B) 25 C) 30 D) 35 E) 40

5. Tümleri ile bütünlerinin oranı  $\frac{7}{16}$  olan açı kaç derecedir?

(What is the angle whose ratio of supplement and complement is  $\frac{7}{16}$ ?)

- A) 10 B) 15 C) 20 D) 25 E) 30

6. Bütünleri tümlerinin 3 katından 20 eksik olan açı kaç derecedir?

(What is the angle whose supplementary is less than 3 times 20 of complementary?)

- A) 55 B) 50 C) 45 D) 35 E) 40

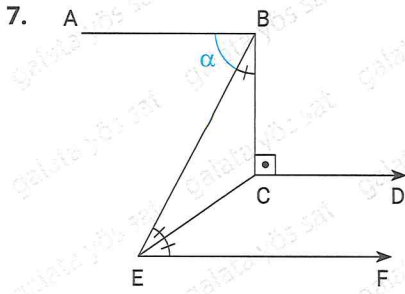

$[BA \parallel [CD \parallel [EF, [BC \perp [CD]$

$$m(\widehat{EBC}) = m(\widehat{BEC}) = m(\widehat{CEF})$$

**Yukarıdaki verilere göre,  $m(\widehat{ABE}) = \alpha$  kaç derecedir?**

(Based on the above data, how many degrees is  $m(\widehat{ABE}) = \alpha$ ?)

- A) 30 B) 35 C) 40 D) 45 E) 60

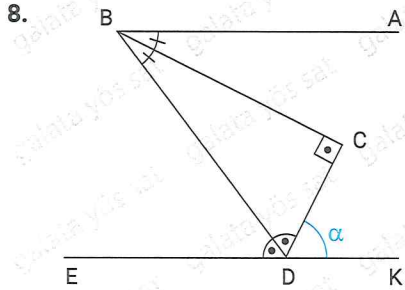

$[BA \parallel [DE, [BC \perp [CD]$

$$m(\widehat{ABC}) = m(\widehat{CBD}), m(\widehat{CDB}) = m(\widehat{BDE})$$

**Yukarıdaki verilere göre,  $m(\widehat{CDK}) = \alpha$  kaç derecedir?**

(Based on the above data, how many degrees is  $m(\widehat{CDK}) = \alpha$ ?)

- A) 45 B) 60 C) 80 D) 90 E) 95

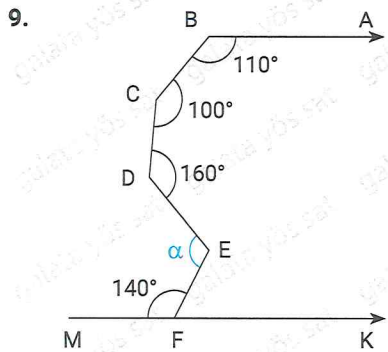

$BA \parallel [FK$

$$m(\widehat{ABC}) = 110^\circ$$

$$m(\widehat{BCD}) = 100^\circ$$

$$m(\widehat{CDE}) = 160^\circ$$

$$m(\widehat{EFM}) = 140^\circ$$

**Yukarıdaki verilere göre,  $m(\widehat{DEF}) = \alpha$  kaç derecedir?**

(Based on the above data, how many degrees is  $m(\widehat{DEF}) = \alpha$ ?)

- A) 10 B) 20 C) 30 D) 40 E) 50

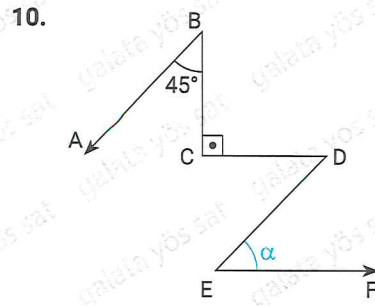

$[BA \parallel [DE]$

$[CD \parallel [EF]$

$[BC \perp [CD]$

**Yukarıdaki verilere göre,  $m(\widehat{DEF}) = \alpha$  kaç derecedir?**

(Based on the above data, how many degrees is  $m(\widehat{DEF}) = \alpha$ ?)

- A) 30 B) 45 C) 60 D) 80 E) 90

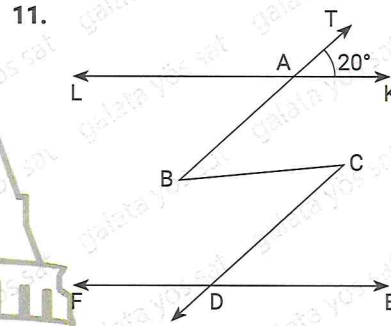

$LK \parallel FE$

$[BT \parallel [CD$

$m(\widehat{TAK}) = 20^\circ$

**Yukarıdaki verilere göre,  $m(\widehat{FDC})$  kaç derecedir?**

(Based on the above data, how many degrees is  $m(\widehat{FDC}) = \alpha$ ?)

- A) 160 B) 140 C) 120 D) 100 E) 80

12.  $d_1 \parallel d_2 \parallel d_3$

$$m(\widehat{CBD}) = x$$

$$m(\widehat{EDF}) = 2x$$

$$m(\widehat{ABC}) = 4x$$

$$m(\widehat{BDE}) = 60^\circ$$

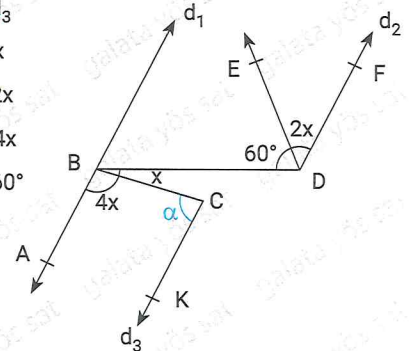

**Yukarıdaki verilere göre,  $m(\widehat{BCK}) = \alpha$  kaç derecedir?**

(Based on the above data, how many degrees is  $m(\widehat{BCK}) = \alpha$ ?)

- A) 60 B) 80 C) 100 D) 110 E) 120

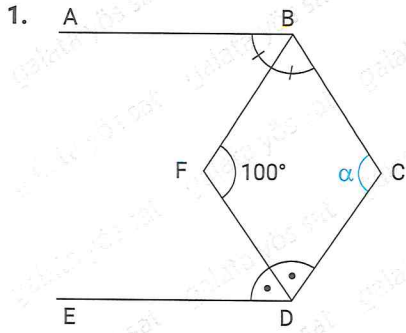

$$[BA \parallel [DE, m(\widehat{BFD}) = 100^\circ$$

$$m(\widehat{ABF}) = m(\widehat{FBC}), m(\widehat{CDF}) = m(\widehat{FDE})$$

Yukarıdaki verilere göre,  $m(\widehat{BCD}) = \alpha$  kaç derecedir?

(Based on the above data, how many degrees is  $m(\widehat{BCD}) = \alpha$ ?)

- A) 100 B) 120 C) 140 D) 150 E) 160

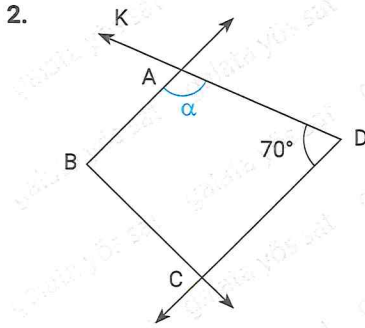

$$[BA \perp [BC \\ [DC \perp [BC \\ m(\widehat{CDA}) = 70^\circ$$

Yukarıdaki verilere göre,  $m(\widehat{BAD}) = \alpha$  kaç derecedir?

(Based on the above data, how many degrees is  $m(\widehat{BAD}) = \alpha$ ?)

- A) 70 B) 90 C) 100 D) 110 E) 120

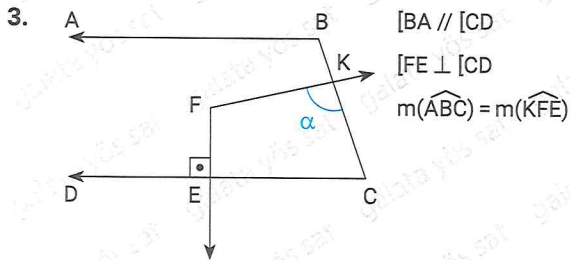

$$[BA \parallel [CD \\ [FE \perp [CD \\ m(\widehat{ABC}) = m(\widehat{KFE})$$

Yukarıdaki verilere göre  $m(\widehat{CKF}) = \alpha$  kaç derecedir?

(Based on the above data, how many degrees is  $m(\widehat{CKF}) = \alpha$ ?)

- A) 60 B) 75 C) 90 D) 120 E) 135

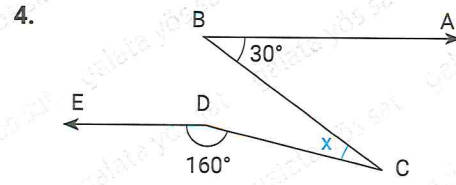

$$[BA \parallel [DE$$

$$m(\widehat{ABC}) = 30^\circ$$

$$m(\widehat{EDC}) = 160^\circ$$

Yukarıdaki verilere göre  $m(\widehat{BCD}) = x$  kaç derecedir?

(Based on the above data, how many degrees is  $m(\widehat{BCD}) = \alpha$ ?)

- A) 5 B) 10 C) 15 D) 30 E) 40

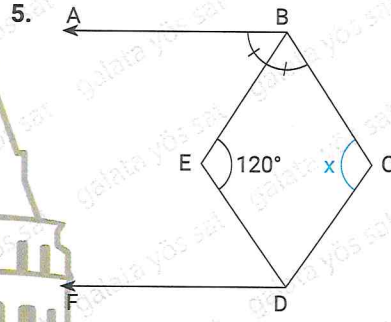

$$[BA \parallel [DF, m(\widehat{ABE}) = m(\widehat{EBC})$$

$$m(\widehat{EDF}) = m(\widehat{CDF}) + 10, m(\widehat{BED}) = 120^\circ$$

Yukarıdaki verilere göre  $m(\widehat{BCD}) = x$  kaç derecedir?

(Based on the above data, how many degrees is  $m(\widehat{BCD}) = x$ ?)

- A) 100 B) 120 C) 130 D) 140 E) 150

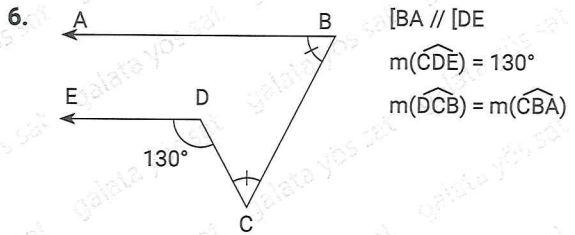

$$[BA \parallel [DE$$

$$m(\widehat{CDE}) = 130^\circ$$

$$m(\widehat{DCB}) = m(\widehat{CBA})$$

Yukarıdaki verilere göre,  $m(\widehat{ABC})$  kaç derecedir?

(Based on the above data, how many degrees is  $m(\widehat{ABC})$ ?)

- A) 45 B) 50 C) 60 D) 65 E) 75

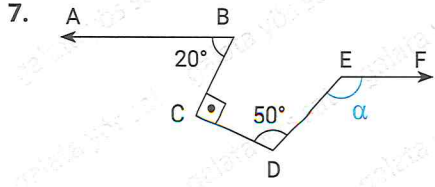

$$[BA \parallel EF, m(\widehat{ABC}) = 20^\circ$$

$$m(\widehat{BCD}) = 90^\circ, m(\widehat{CDE}) = 50^\circ$$

Yukarıdaki verilere göre,  $m(\widehat{FED}) = \alpha$  kaç derecedir?

(Based on the above data, how many degrees is  $m(\widehat{FED}) = \alpha$ ?)

- A) 120 B) 140 C) 150 D) 160 E) 165

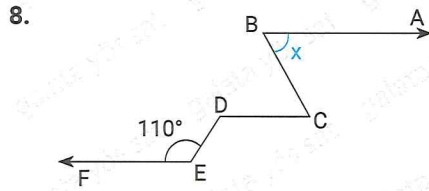

$$[BA \parallel CD] \parallel [EF$$

$$m(\widehat{CDE}) = m(\widehat{BCD}) + 40$$

Yukarıdaki verilere göre,  $m(\widehat{ABC}) = x$  kaç derecedir?

(Based on the above data, how many degrees is  $m(\widehat{ABC}) = x$ ?)

- A) 15 B) 30 C) 45 D) 60 E) 70

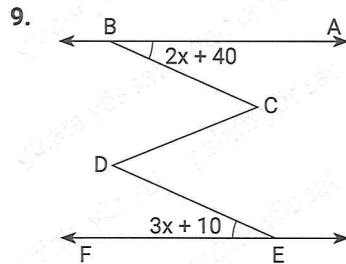

$$[BA \parallel EF$$

$$[BC] \parallel [DE]$$

$$m(\widehat{ABC}) = 2x + 40$$

$$m(\widehat{DEF}) = 3x + 10$$

Yukarıdaki verilere göre,  $x$  kaç derecedir?

(Based on the above data, how many degrees is  $x$ ?)

- A) 10 B) 15 C) 20 D) 25 E) 30

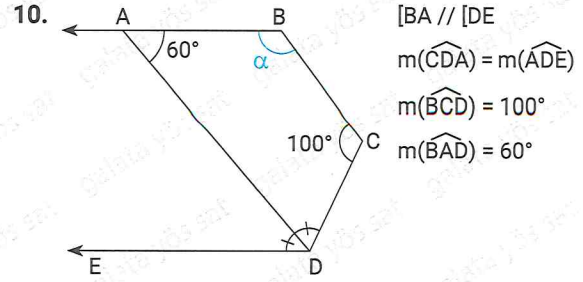

$$[BA \parallel DE$$

$$m(\widehat{CDA}) = m(\widehat{ADE})$$

$$m(\widehat{BCD}) = 100^\circ$$

$$m(\widehat{BAD}) = 60^\circ$$

Yukarıdaki verilere göre  $m(\widehat{ABC}) = \alpha$  kaç derecedir?

(Based on the above data, how many degrees is  $m(\widehat{ABC}) = \alpha$ ?)

- A) 100 B) 130 C) 140 D) 150 E) 160

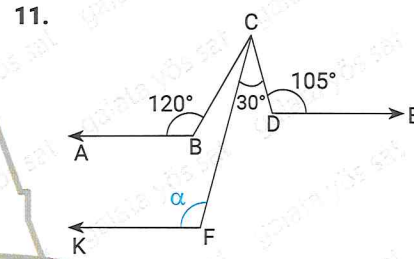

$$[BA \parallel DE \parallel [FK, m(\widehat{ABC}) = 120^\circ$$

$$m(\widehat{FCD}) = 30^\circ, m(\widehat{CDE}) = 105^\circ$$

Yukarıdaki verilere göre,  $m(\widehat{CFK}) = \alpha$  kaç derecedir?

(Based on the above data, how many degrees is  $m(\widehat{CFK}) = \alpha$ ?)

- A) 100 B) 105 C) 110 D) 115 E) 120

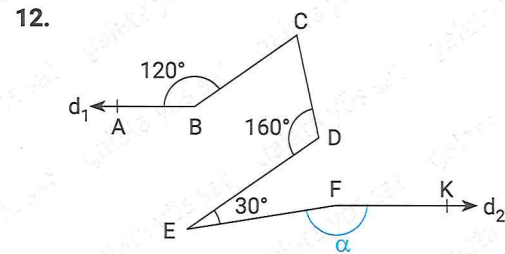

$$d_1 \parallel d_2, [BC] \parallel [ED]$$

$$m(\widehat{DEF}) = 30^\circ, m(\widehat{ABC}) = 120^\circ, m(\widehat{CDE}) = 160^\circ$$

Yukarıdaki verilere göre  $m(\widehat{EFK}) = \alpha$  kaç derecedir?

(Based on the above data, how many degrees is  $m(\widehat{EFK}) = \alpha$ ?)

- A) 150 B) 140 C) 130 D) 120 E) 110

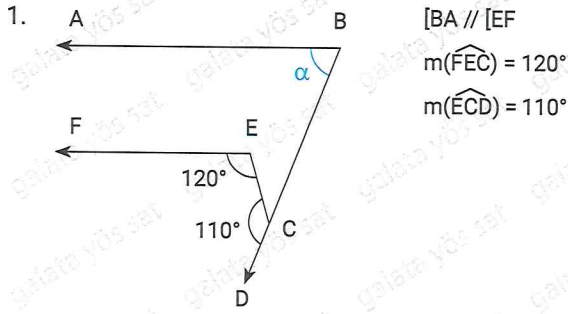

Yukarıdaki verilere göre,  $m(\widehat{ABC}) = \alpha$  kaç derecedir?

(Based on the above data, how many degrees is  $m(\widehat{ABC}) = \alpha$ ?)

- A) 50 B) 60 C) 70 D) 85 E) 95

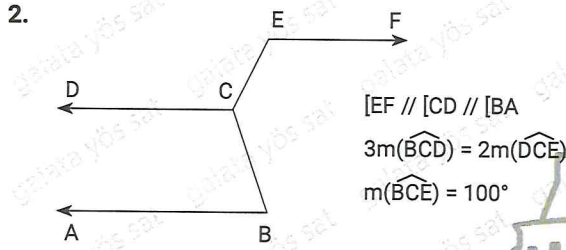

Yukarıdaki verilere göre  $m(\widehat{ABC})$  kaç derecedir?

(Based on the above data, how many degrees is  $m(\widehat{ABC})$ ?)

- A) 70 B) 76 C) 80 D) 86 E) 106

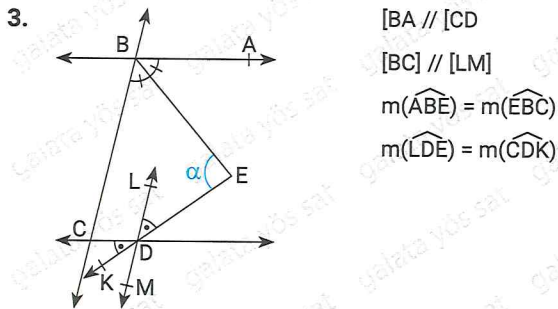

Yukarıdaki verilere göre  $m(\widehat{BED}) = \alpha$  kaç derecedir?

(Based on the above data, how many degrees is  $m(\widehat{BED}) = \alpha$ ?)

- A) 60 B) 70 C) 80 D) 90 E) 100

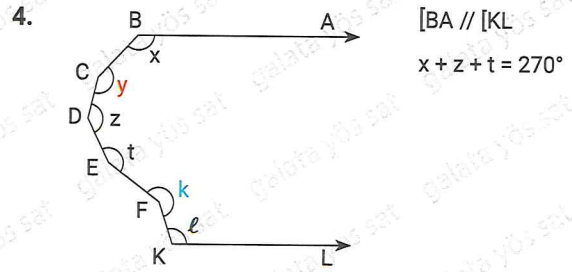

olduğuna göre,  $y + k + l$  açısı kaç tane dik açı eder?

(How many right angles does the angle  $y + k + l$  make?)

- A) 5 B) 6 C) 7 D) 8 E) 10

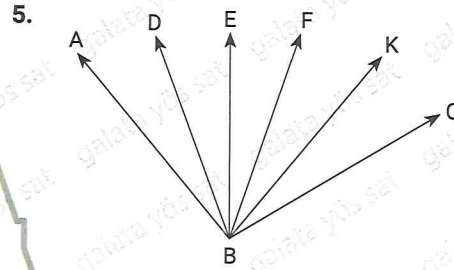

[BE, ABK'nın, [BK, FBC'nin açıortayıdır (bisector).

$m(\widehat{EBF}) = 10^\circ$ ,  $m(\widehat{ABC}) = 110^\circ$

Yukarıda verilere göre  $m(\widehat{ABK})$  kaç derecedir?

(Based on the above data, how many degrees is  $m(\widehat{ABK})$ ?)

- A) 60 B) 80 C) 90 D) 95 E) 100

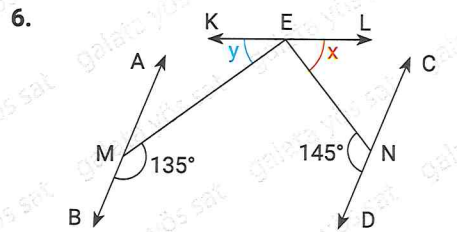

AB // CD,  $m(\widehat{BME}) = 135^\circ$ ,  $m(\widehat{DNE}) = 145^\circ$

$m(\widehat{KEM}) = y$ ,  $m(\widehat{LEN}) = x$

Yukarıda verilere göre  $x + y$  nedir?

(Based on the above data, what is  $x+y$ ?)

- A) 80 B) 90 C) 100 D) 110 E) 120



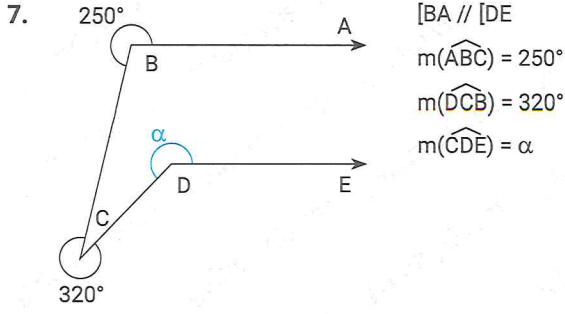

Yukarıda verilere göre  $m(\widehat{CDE}) = \alpha$  nedir?

(Based on the above data, how many degrees is  $m(\widehat{CDE}) = \alpha$ ?)

- A) 150 B) 170 C) 190 D) 200 E) 210

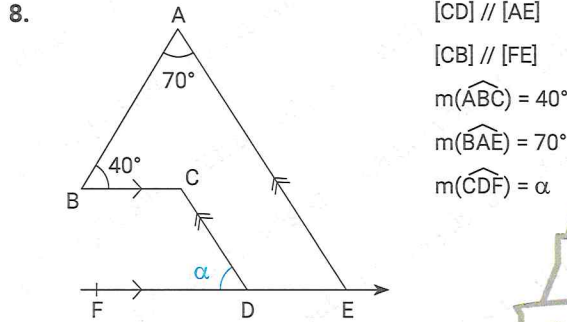

Yukarıda verilere göre  $\alpha$  kaç derecedir?

(Based on the above data, how many degrees is  $\alpha$ ?)

- A) 65 B) 70 C) 75 D) 80 E) 85

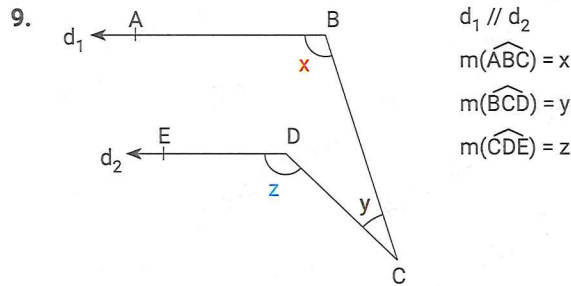

y'nin x ve z cinsinden değeri nedir?

(What is y in terms of z?)

- A)  $y = x + z$  B)  $y = x - z + 90$   
 C)  $y = z - x$  D)  $y = x + z + 180$   
 E)  $y = x + z + 270$

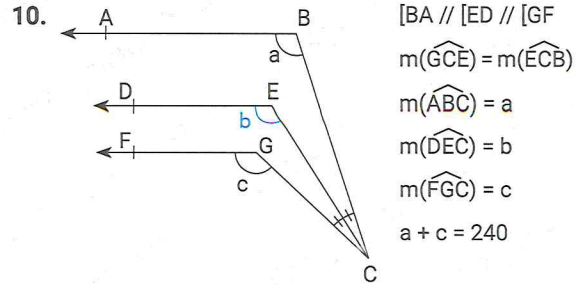

Yukarıdaki verilere göre, b kaç derecedir?

(Based on the above data, how many degrees is b?)

- A) 100 B) 110 C) 120 D) 130 E) 140

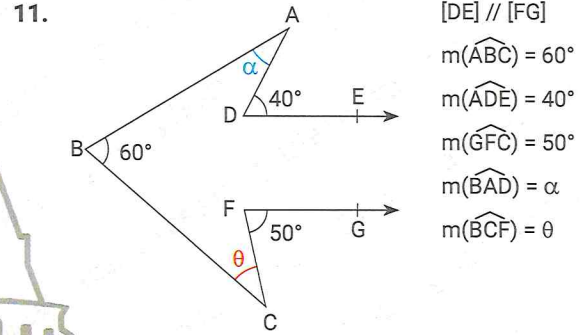

Yukarıdaki verilere göre,  $\alpha + \theta$  kaç derecedir?

(Based on the above data, how many degrees is  $\alpha + \theta$ ?)

- A) 45 B) 40 C) 35 D) 30 E) 25

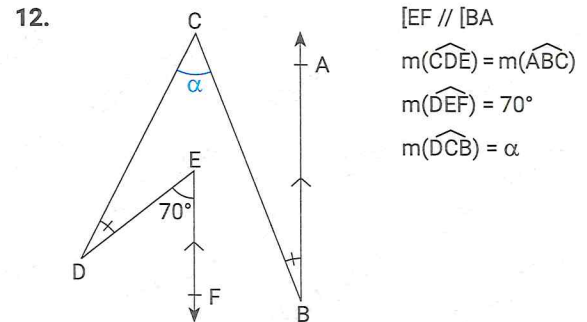

Yukarıdaki verilere göre,  $\alpha$  kaç derecedir?

(Based on the above data, how many degrees is  $\alpha$ ?)

- A) 70 B) 65 C) 60 D) 40 E) 35

1.

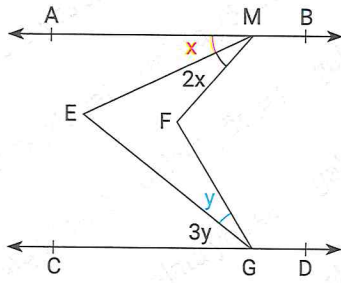

$AB \parallel CD$   
 $m(\widehat{MFG}) = 125^\circ$   
 $m(\widehat{MEG}) = 75^\circ$

Yukarıdaki verilere göre,  $x + y$  kaç derecedir?

(Based on the above data, how many degrees is  $x + y$ ?)

- A) 35 B) 40 C) 30 D) 20 E) 45

2018

2.

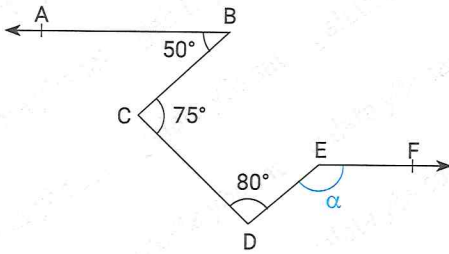

$[BA \parallel [EF, m(\widehat{ABC}) = 50^\circ$   
 $m(\widehat{BCD}) = 75^\circ, m(\widehat{CDE}) = 80^\circ$

Yukarıdaki verilere göre,  $m(\widehat{DEF}) = \alpha$  kaç derecedir?

(Based on the above data, how many degrees is  $m(\widehat{DEF}) = \alpha$ ?)

- A) 100 B) 105 C) 110 D) 115 E) 120

2017

3.

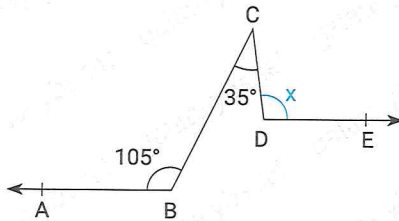

$[BA \parallel [DE, m(\widehat{BCD}) = 35^\circ, m(\widehat{ABC}) = 105^\circ$

Yukarıdaki verilere göre  $m(\widehat{CDE}) = x$  kaç derecedir?

(Based on the above data, how many degrees is  $m(\widehat{CDE}) = x$ ?)

- A) 80 B) 95 C) 100 D) 110 E) 115

2013

4.

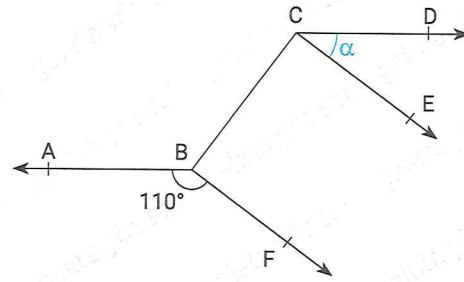

$[BA \parallel [CD, [BF \parallel [CE, m(\widehat{ABF}) = 110^\circ$

Yukarıdaki verilere göre,  $m(\widehat{DCE}) = \alpha$  kaç derecedir?

(Based on the above data, how many degrees is  $m(\widehat{DCE}) = \alpha$ ?)

- A) 30 B) 40 C) 50 D) 60 E) 70

2014

5.

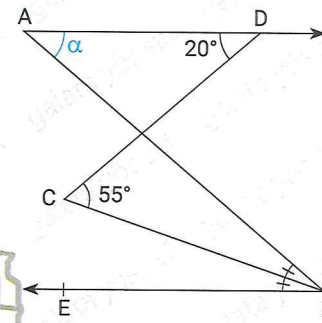

$[AD \parallel [BE$   
 $[BC; \text{açıortay}$   
 $m(\widehat{ADC}) = 20^\circ$   
 $m(\widehat{BCD}) = 55^\circ$

Yukarıdaki verilere göre,  $m(\widehat{BAD}) = \alpha$  kaç derecedir?

(Based on the above data, how many degrees is  $m(\widehat{BAD}) = \alpha$ ?)

- A) 70 B) 65 C) 60 D) 55 E) 50

2018

6.

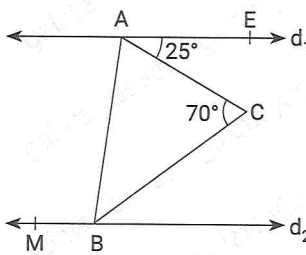

$d_1 \parallel d_2$   
 $|AB| = |BC|$   
 $m(\widehat{EAC}) = 25^\circ$   
 $m(\widehat{ACB}) = 70^\circ$

Yukarıdaki verilere göre  $m(\widehat{ABM})$  kaç derecedir?

(Based on the above data, how many degrees is  $m(\widehat{ABM})$ ?)

- A) 115 B) 110 C) 105 D) 100 E) 95

2017



7.

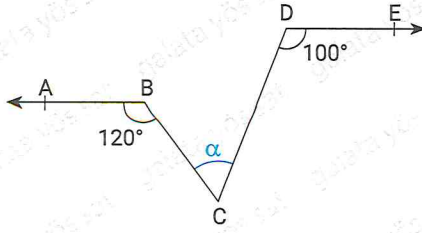

[BA // DE,  $m(\widehat{ABC}) = 120^\circ$ ,  $m(\widehat{CDE}) = 100^\circ$

Yukarıdaki verilere göre,  $m(\widehat{BCD}) = \alpha$  kaç derecedir?

(Based on the above data, how many degrees is  $m(\widehat{BCD}) = \alpha$ ?)

A) 20 B) 40 C) 100 D) 120 E) 220

2018

10.

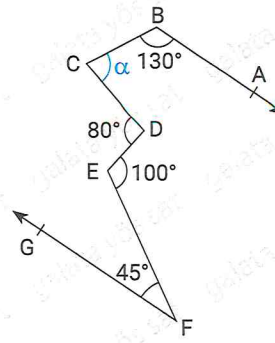

[BA // FG

$m(\widehat{ABC}) = 130^\circ$

$m(\widehat{CDE}) = 80^\circ$

$m(\widehat{DEF}) = 100^\circ$

$m(\widehat{EFG}) = 45^\circ$

Yukarıdaki verilere göre,  $m(\widehat{BCD}) = \alpha$  kaç derecedir?

(Based on the above data, how many degrees is  $m(\widehat{BCD}) = \alpha$ ?)

A) 60 B) 65 C) 70 D) 75 E) 80

2019

8.

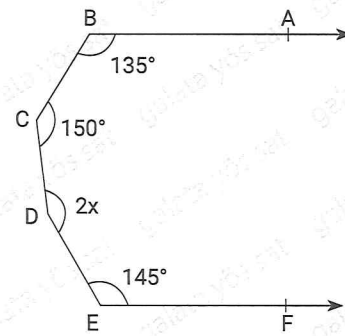

[BA // EF

$m(\widehat{ABC}) = 135^\circ$

$m(\widehat{BCD}) = 150^\circ$

$m(\widehat{CDE}) = 2x$

$m(\widehat{DEF}) = 145^\circ$

Yukarıdaki verilere göre, x kaç derecedir?

(Based on the above data, how many degrees is x?)

A) 40 B) 45 C) 50 D) 55 E) 110

2018

11.

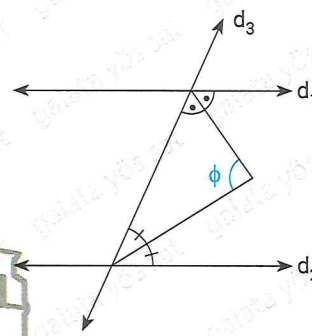

$d_1 // d_2$

Yukarıdaki verilere göre  $\phi$  kaç derecedir?

(Based on the above data, how many degrees is  $\phi$ ?)

A) 180 B) 90 C) 60 D) 45 E) 30

2020

9.

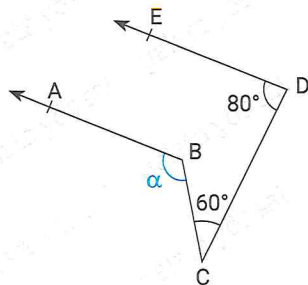

[BA // DE

$m(\widehat{BCD}) = 60^\circ$

$m(\widehat{CDE}) = 80^\circ$

Yukarıdaki verilere göre  $m(\widehat{ABC}) = \alpha$  kaç derecedir?

(Based on the above data, how many degrees is  $m(\widehat{ABC}) = \alpha$ ?)

A) 110 B) 120 C) 140 D) 160 E) 220

2019

12.

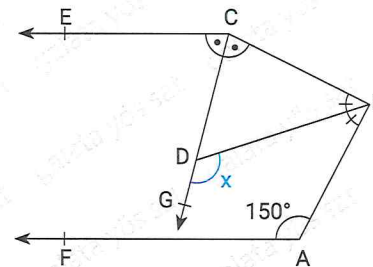

[CE // AF

Yukarıdaki verilere göre, x kaç derecedir?

(Based on the above data, how many degrees is x?)

A) 90 B) 100 C) 105 D) 110 E) 120

2019



1.

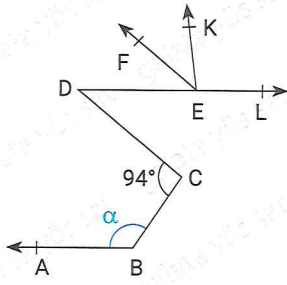

[BA // [DL  
[EF // [DC  
 $m(\widehat{DEF}) = 2m(\widehat{FEK})$   
 $m(\widehat{KEL}) = 87^\circ$   
 $m(\widehat{BCD}) = 94^\circ$

Yukarıdaki verilere göre,  $m(\widehat{ABC}) = \alpha$  kaç derecedir?

(Based on the above data, how many degrees is  $m(\widehat{ABC}) = \alpha$ ?)

- A) 130 B) 138 C) 140 D) 148 E) 150

2.

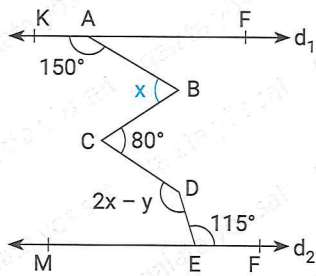

$d_1 // d_2$   
 $m(\widehat{KAB}) = 150^\circ$   
 $m(\widehat{DEF}) = 115^\circ$   
 $m(\widehat{BCD}) = 80^\circ$   
 $m(\widehat{ABC}) = x$   
 $m(\widehat{CDE}) = 2x - y$   
 $x + y = 25$

Yukarıdaki verilere göre, x kaç derecedir?

(Based on the above data, how many degrees is x?)

- A) 60 B) 62,5 C) 70 D) 72,5 E) 80

3.

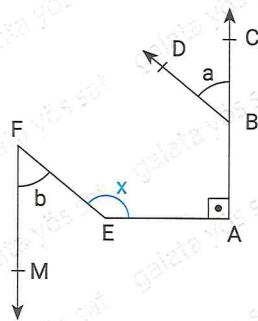

[AC // [FM  
[BD // [EF  
 $m(\widehat{CBD}) = a$   
 $m(\widehat{EFM}) = b$   
 $m(\widehat{AEF}) = x$   
 $a + b = 100$

Yukarıdaki verilere göre, x kaç derecedir?

(Based on the above data, how many degrees is x?)

- A) 130 B) 140 C) 150 D) 160 E) 170

4.

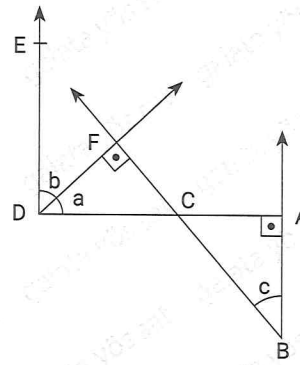

[BA // [DE  
[DF] ⊥ [BF]  
[DA] ⊥ [BA]

Yukarıdaki verilere göre aşağıdakilerden hangisi kesinlikle doğrudur?

(Based on the above data, which of the following is absolutely true?)

- A)  $b = a + c$  B)  $a = 2c$  C)  $a = c$   
D)  $b = a$  E)  $b = 2a$

5.

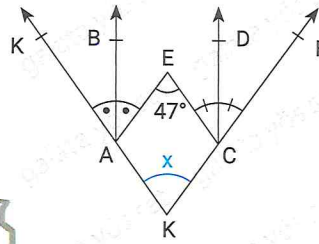

[AB // [CD, [AB] ve [CD] açıortay (bisector),  
 $m(\widehat{AEC}) = 47^\circ$

Yukarıdaki verilere göre,  $m(\widehat{AKC}) = x$  kaç derecedir?

(Based on the above data, how many degrees is  $m(\widehat{AKC}) = x$ ?)

- A) 47 B) 50 C) 53 D) 57 E) 60

6.

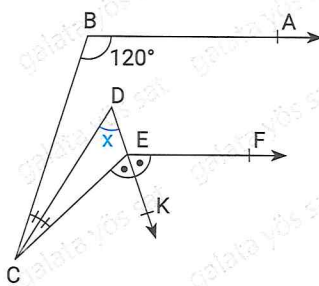

[BA // [EF, [CD] ve [EK] açıortay (bisector),  
 $m(\widehat{ABC}) = 120^\circ$

Yukarıdaki verilere göre,  $m(\widehat{CDK}) = x$  kaç derecedir?

(Based on the above data, how many degrees is  $m(\widehat{CDK}) = x$ ?)

- A) 120 B) 100 C) 90 D) 80 E) 60



7.

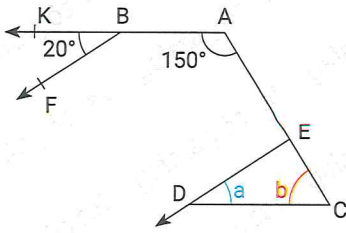

[AK // CD], [BF // ED],  $m(\widehat{FBK}) = 20^\circ$   
 $m(\widehat{BAC}) = 150^\circ$ ,  $m(\widehat{EDC}) = a^\circ$ ,  $m(\widehat{ECD}) = b^\circ$

**Yukarıdaki verilere göre,  $b - a$  kaçtır?**

(Based on the above data, what is  $b - a$ ?)

- A) 10    B) 20    C) 30    D) 50    E) 60

8.

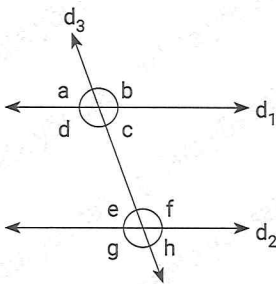

$d_1 // d_2$

- I.  $a = h$   
 II.  $b = g$   
 III.  $d + h = 180^\circ$   
 IV.  $g + c = 180^\circ$   
 V.  $e + a = 180^\circ$

**Yukarıdaki bilgilerden kaç tanesi doğrudur?**

(How many of the above information is true?)

- A) 1    B) 2    C) 3    D) 4    E) 5

9.

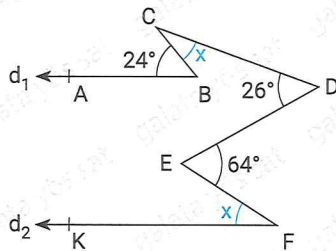

[BA // FK],  $m(\widehat{ABC}) = 24^\circ$ ,  $m(\widehat{CDE}) = 26^\circ$   
 $m(\widehat{DEF}) = 64^\circ$ ,  $m(\widehat{BCD}) = m(\widehat{EFK}) = x$

**Yukarıdaki verilere göre,  $x$  kaçtır?**

(Based on the above data, what is  $x$ ?)

- A) 26    B) 28    C) 31    D) 35    E) 40

10.

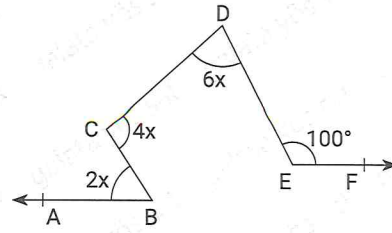

[BA // EF],  $m(\widehat{ABC}) = 2x$ ,  $m(\widehat{BCD}) = 4x$   
 $m(\widehat{CDE}) = 8x$ ,  $m(\widehat{DEF}) = 100^\circ$

**Yukarıdaki verilere göre,  $x$  kaçtır?**

(Based on the above data, what is  $x$ ?)

- A) 12,5    B) 20    C) 22,5    D) 40    E) 50

11.

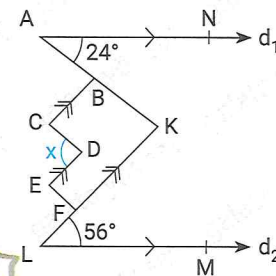

$d_1 // d_2$   
 [BC] // [DE] // [KF]  
 $m(\widehat{NAB}) = 24^\circ$   
 $m(\widehat{KLM}) = 56^\circ$

**Yukarıdaki verilere göre,  $m(\widehat{CDE}) = x$  kaç derecedir?**

(Based on the above data, how many degrees is  $m(\widehat{CDE}) = x$ ?)

- A) 48    B) 50    C) 54    D) 68    E) 80

12.

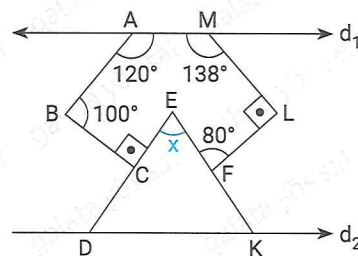

$d_1 // d_2$ ,  $m(\widehat{MAB}) = 120^\circ$ ,  $m(\widehat{AML}) = 138^\circ$   
 $m(\widehat{ABC}) = 100^\circ$ ,  $m(\widehat{EFL}) = 80^\circ$

**Yukarıdaki verilere göre,  $x$  kaçtır?**

(Based on the above data, what is  $x$ ?)

- A) 60    B) 68    C) 70    D) 78    E) 80

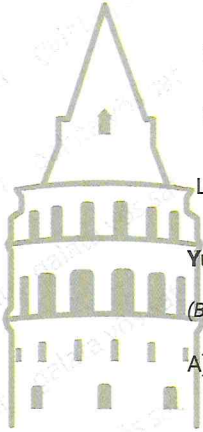

# ÜNİTE 2

## Unit 2

### Üçgende Açılar

### *Angles in Triangle*



Üçgende Açılar / Angles in Triangle

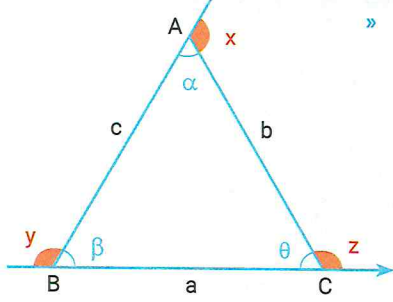

» Doğrusal olmayan üç noktanın birleştirilmesiyle oluşan kapalı geometrik şekle **üçgen** denir.  
(The closed geometric shape formed by joining three nonlinear points is called a **triangle**.)

$\widehat{ABC}$ 'de

- A, B, C üçgenin köşeleri (The vertices of the triangle A, B, C)
- a, b, c üçgenin kenarları (sides of a, b, c triangle)
- $\alpha, \beta, \theta$  üçgenin iç açıları (interior angles of  $\alpha, \beta, \theta$  triangle)
- x, y, z üçgenin dış açılarıdır (x, y, z are the outer angles of the triangle).

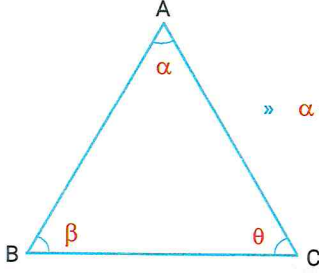

»  $\alpha + \beta + \theta = 180^\circ$

» Üçgenin iç açıları toplamı  $180^\circ$ 'dir.  
(The sum of the angles of the triangle is  $180^\circ$ .)

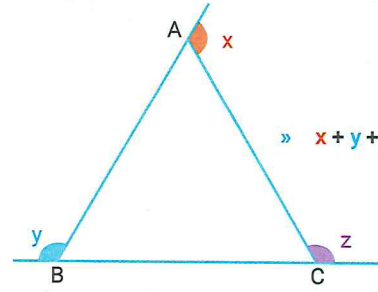

»  $x + y + z = 360^\circ$

» Üçgenin dış açıları toplamı  $360^\circ$ 'dir.  
(The sum of the exterior angles of the triangle is  $360^\circ$ .)

1)

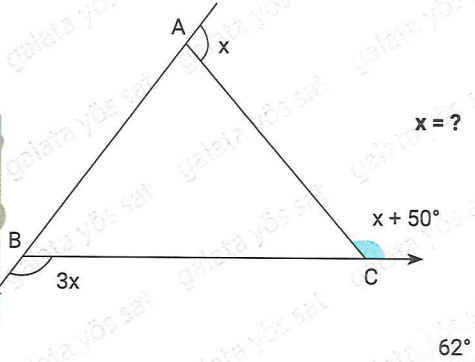
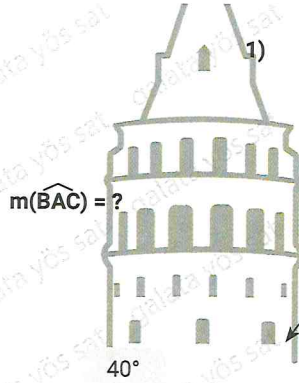
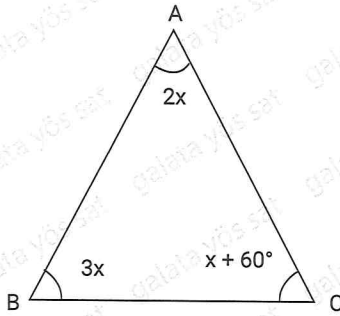

2)

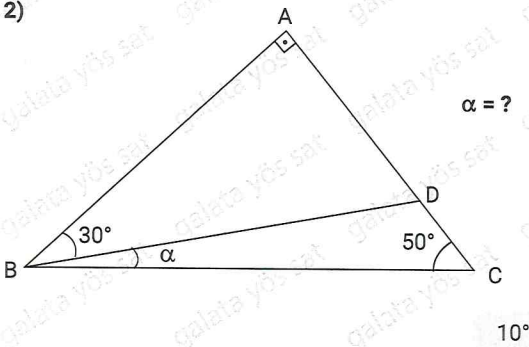

2)

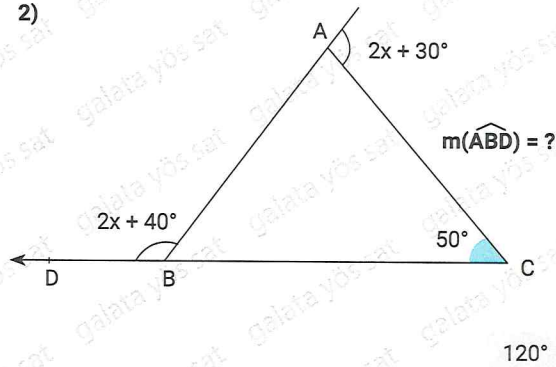

İpucu (Tip) / Hint

- Önce hangi üçgenden başlayacağını farket!  
(Notice which triangle to start from first!)
- Bilginin çok olduğu üçgeni bulup üçüncü açığı tamamla-  
yalım.  
(Let's find the triangle with a lot of information and complete  
the third angle.)

İpucu (Tip) / Hint

- Açıların bulunduğu yeri hisset ve ona göre işlem yap!  
(Feel where the angles are and act accordingly!)
- Yani verilen bilgiler üçgenin iç açısı mı yoksa dış açısı mı?



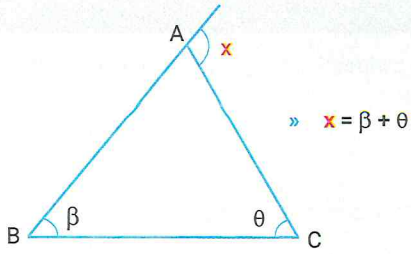

» Üçgende, bir dış açı komşusu olmayan iki iç açının toplamına eşittir. (In triangle, one exterior angle is equal to the sum of two interior angles that are not neighbors.)

